

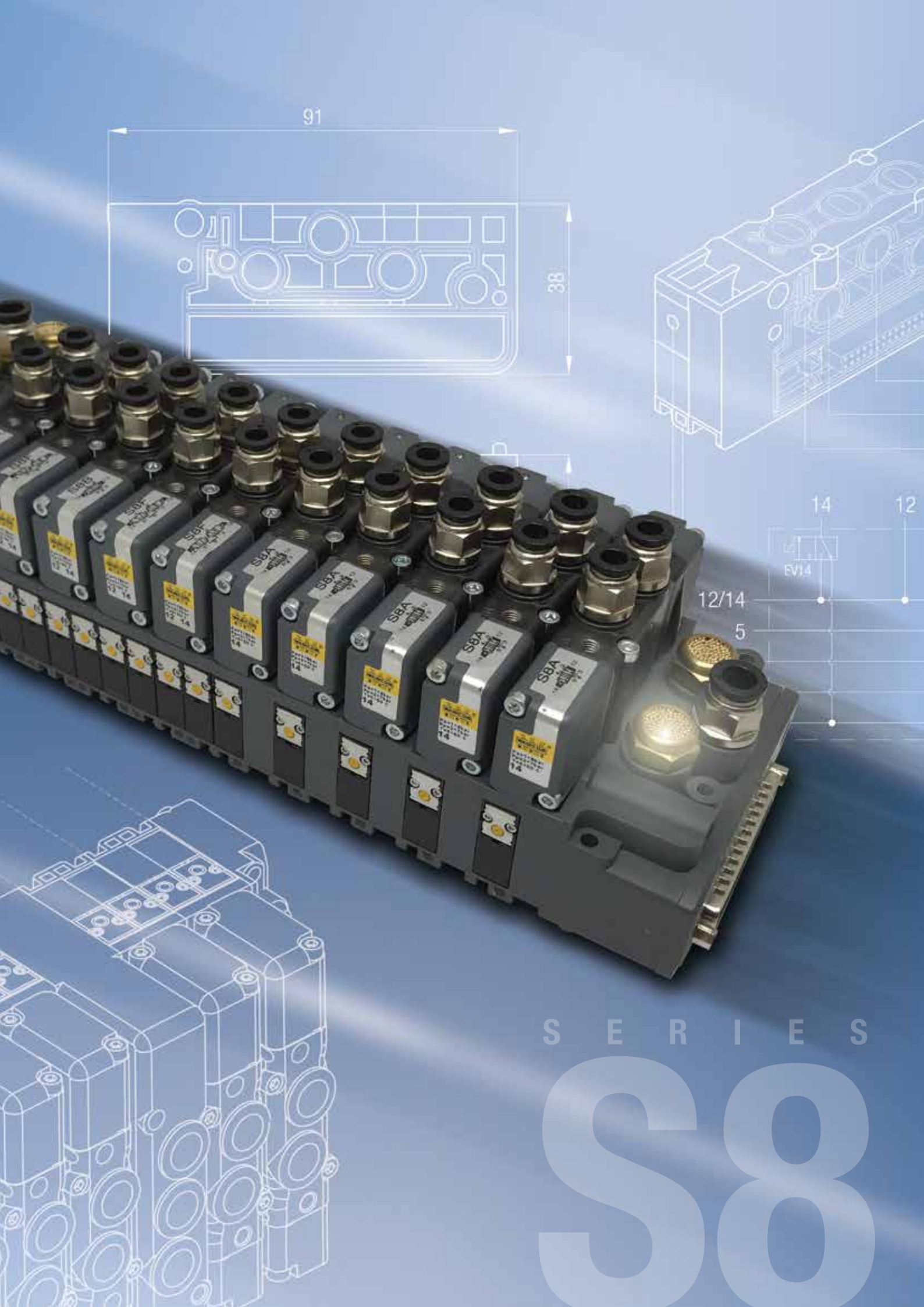

MANIFOLD MOUNTING OF VALVES WITH MULTI-PIN CONNECTION

S E R I E S

S8



91

38

14

12

EV14

12/14

5

S E R I E S

S8

DESCRIPTION

The series "S8" is the new family of solenoid valves mounted on manifold bases whose integrated electrical part is capable of handling up to 32 signals thanks to the multi-pin connection. The valves belonging to this series are characterized by compact overall dimensions, high flow-rate and by a very smart engineering process resulted in just a few components needed for the assembly. The reduced overall dimensions allow to assemble the manifold both in a "vertical" or "horizontal" position, depending from the different mounting requirements. This series of valves comes with all the pneumatic functions requested by the market, including the "2x2/2" and "2x3/2" versions. They can comply with ATEX directive, 3GD category, upon request.



TECHNICAL DATA

Operating pressure (port 1, 3 and 5)	-1 ÷ 8 bar
Piloting pressure (port 12/14)	2.5 ÷ 7 bar
Working temperature	0 ÷ 50 °C
Fluid	Compressed air, filtered, continuous lubricated, unlubricated or dry lubricated
Air purity class	Class 3-4-3 to ISO 8573-1 standard
Port size	Inlet & exhaust port on input module: G1/4; Inlet & exhaust port on intermediate bases: G1/8; Outlet lines: G1/8; Supply & exhaust port on piloting valves: M5
Protection class	IP 65 to EN 60529
Voltage	24 VDC ±10%
Single solenoid consumption	1,44 W (60 mA)
Duty cycle	Continuous rating ED100%
Max No. of solenoids	22 with a 25-pins sub-D plug 32 with a 37-pins sub-D plug

MATERIALS

Bottoms	Techno-polymer
Body	Cast painted aluminium alloy
Distance ring	Acetal resin - brass
Spools	Nickel-plated steel
Springs	Stainless steel
Pistons	Anodized aluminium alloy
Seals	NBR rubber
Manifold	Techno-polymer
Tie-rods	Stainless steel

FLOW CHART

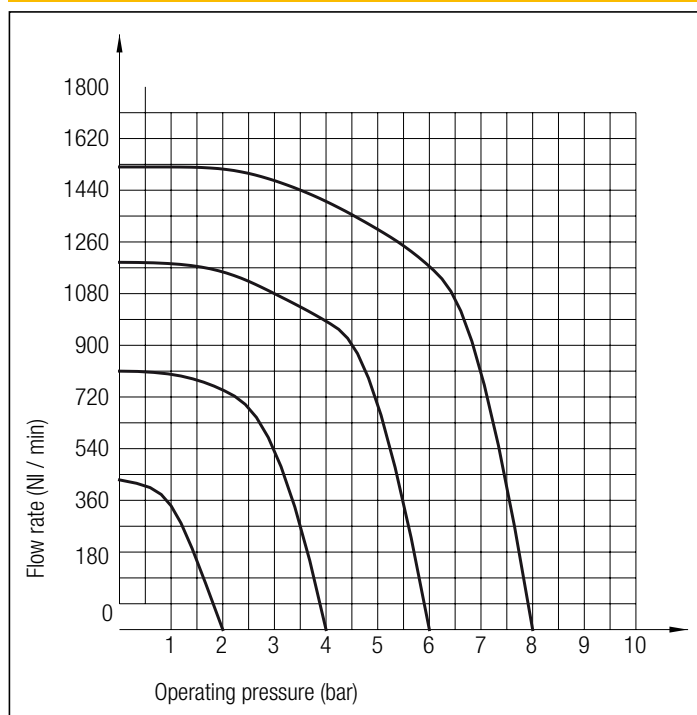

PILOTING CHART

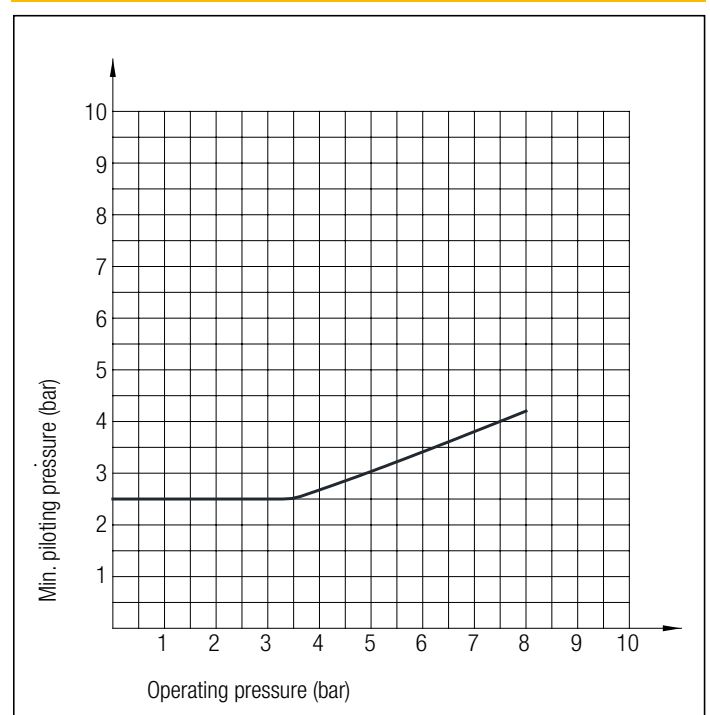

ORDER KEY FOR MANIFOLD MOUNTING IN THE MULTI-PIN CONNECTION VERSION

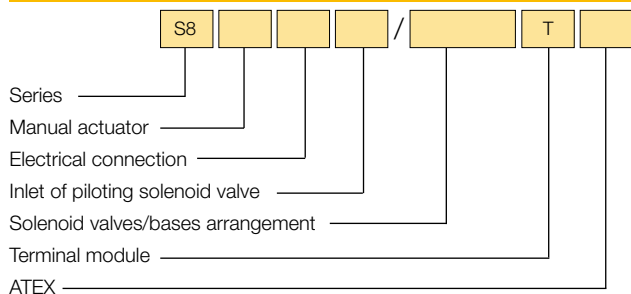

MANUAL ACTUATOR OF PILOTING SOLENOID VALVES

M Monostable

ELECTRICAL CONNECTION

D25 Sub-D 25 pins

D37 Sub-D 37 pins

INLET OF PILOTING SOLENOID VALVE

D Internal

I External

SOLENOID VALVES/BASES ARRANGEMENT*

A 5/2 Monostable

B 5/2 Bistable

C 5/3 Closed centre

E 3/2 N.O. + 3/2 N.O.

F 3/2 N.C. + 3/2 N.C.

G 3/2 N.C. + 3/2 N.O.

H 2/2 N.O. + 2/2 N.O.

I 2/2 N.C. + 2/2 N.C.

L 2/2 N.C. + 2/2 N.O.

M Intermediate base with through ducts

N Intermediate base with duct "1" closed

O Intermediate base with ducts "1", "3" and "5" closed

P Intermediate base with ducts "3" and "5" closed

Q Monostable base with closing plate (fit for mounting the S8A valve)

R Bistable base with closing plate (fit for mounting the S8B, S8C, S8E, S8F, S8G, S8H, S8I, S8L)

TERMINAL MODULE

T Blind terminal module

ATEX

/EX Consistent with the ATEX directive  II 3G c Ex nA IIC T5 Gc -5°C ≤ Ta ≤ 50°C
II 3D c Ex tc IIIC T100°C IP65 Dc

* NB: When there are same and consecutive types, indicate at first the letter referring to the solenoid valves/bases and then the number stating how many of them must be assembled consecutively.

For example: S8MD25D/AAAFFFFGG becomes S8MD25D/A3F4G2

ORDER EXAMPLE

Manifold mounting with input module with sub-D 25 pins plug and internal inlet.
Monostable actuator of the piloting solenoid valve.
Solenoid valves and intermediate bases arrangement (starting from the input module):

- 1 5/2 Monostable
- 2 5/2 Monostable
- 3 5/2 Bistable
- 4 3/2 N.C. + 3/2 N.C.
- 5 3/2 N.C. + 3/2 N.C.
- 6 Intermediate base with through ducts

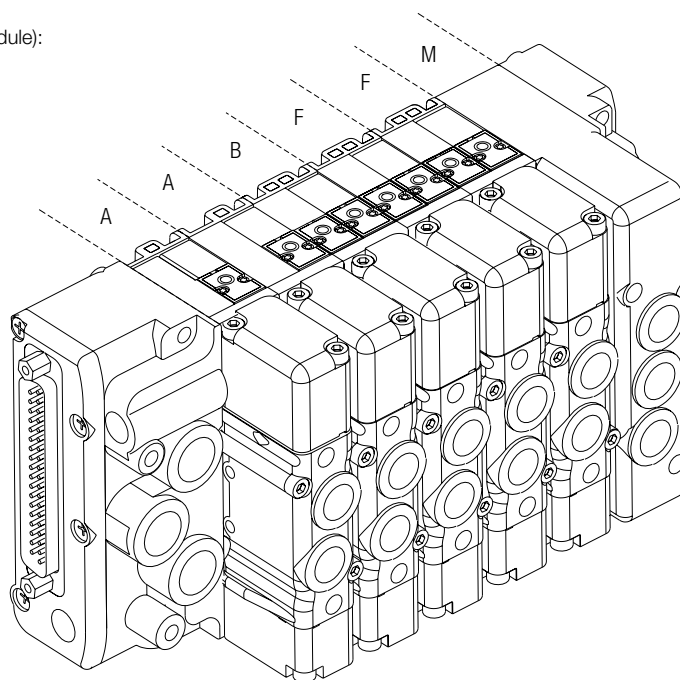
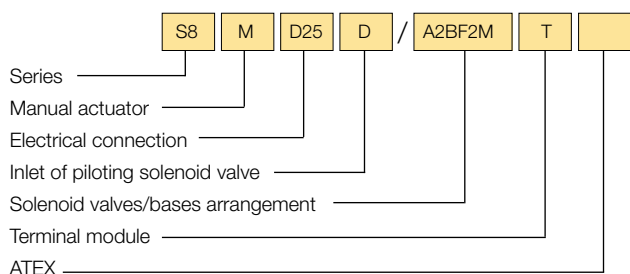

ORDER EXAMPLE

Manifold mounting with input module with sub-D 37 pins plug and external inlet.
Monostable actuator of the piloting solenoid valve.
Solenoid valves and intermediate bases arrangement (starting from the input module):

- 1 5/2 Monostable
- 2 5/2 Monostable
- 3 5/2 Bistable
- 4 Intermediate base with ducts 1, 3 & 5 closed
- 5 5/3 Closed centre
- 6 5/3 Closed centre

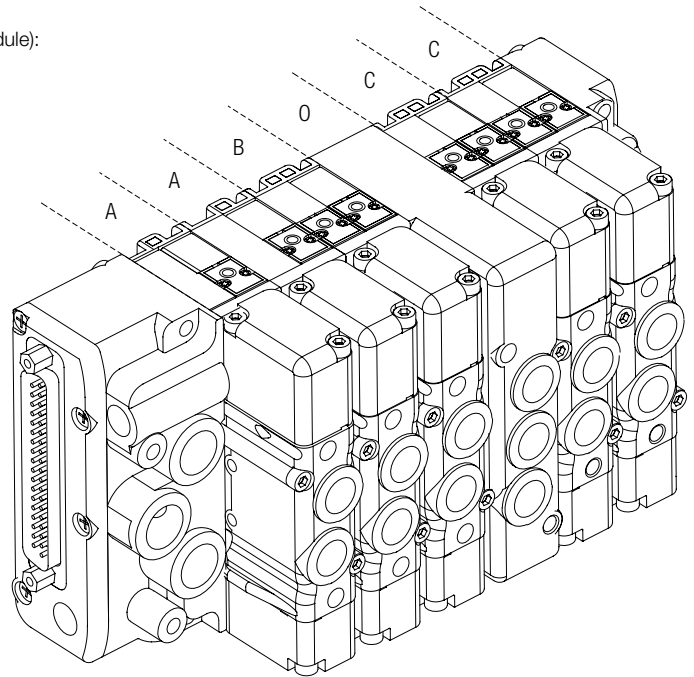
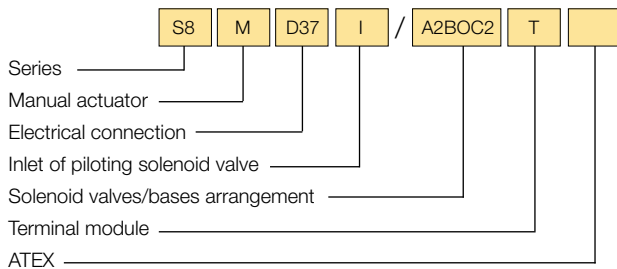

ORDER EXAMPLE

Manifold mounting with input module with sub-D 37 pins plug and internal inlet.
Monostable actuator of the piloting solenoid valve.
Solenoid valves and intermediate bases arrangement (starting from the input module):

- 1 5/2 Monostable
- 2 5/2 Monostable
- 3 5/2 Monostable
- 4 5/2 Monostable
- 5 5/2 Monostable
- 6 5/2 Monostable

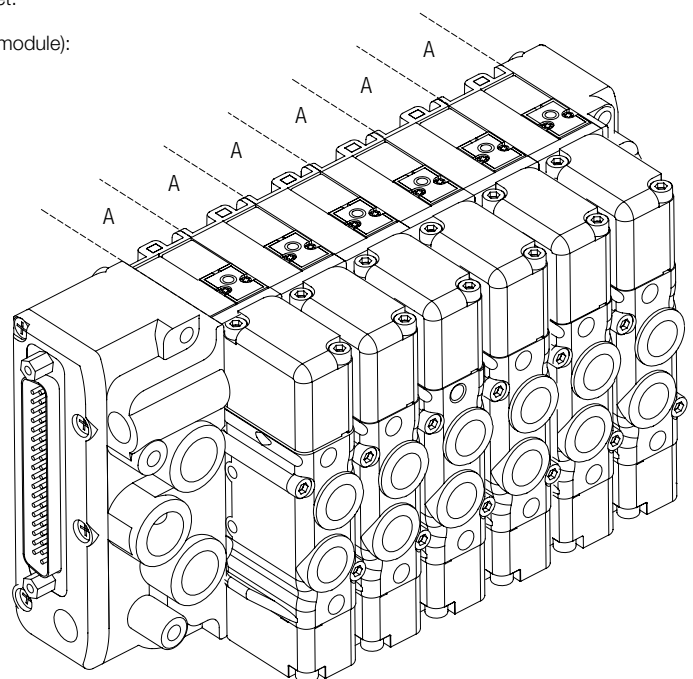
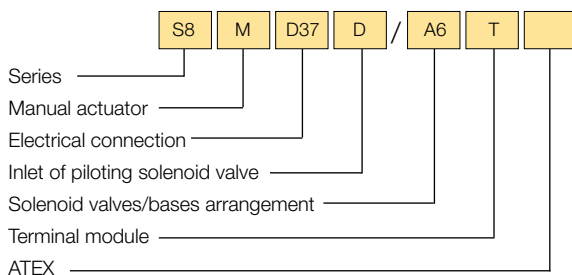

PARTS LIST

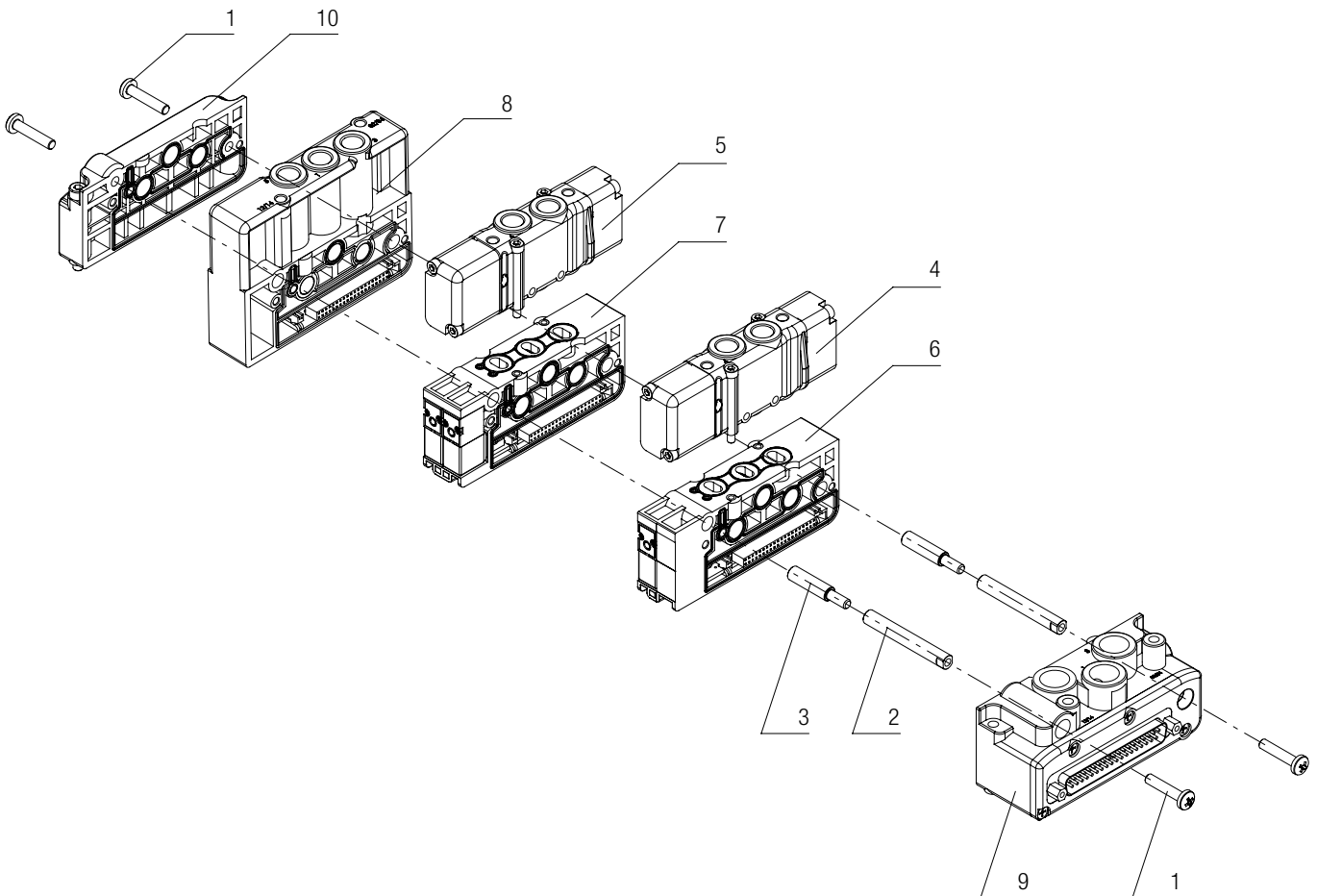

1	Tightening screws
2	Tie-rods
3	Junction nipple for odd stations or to add a station
4	Valve with pneumatic function type "A" (5/2 monostable)
5	Valve with pneumatic functions type "B", "C", "E", "F", "G", "H", "I", "L"
6	Modular base with single solenoid for 5/2 monostable valve ("A")
7	Modular base with for valves type "B", "C", "E", "F", "G", "H", "I", "L"
8	Intermediate modular base with auxiliary inlets/exhausts
9	Input module
10	Terminal module

INPUT MODULE WITH INTERNAL INLET FOR PILOTING SOLENOID VALVES - SBTD ...

S8TD25 - INPUT MODULE WITH INTERNAL INLET FOR PILOTING SOLENOID VALVES AND 25-PINS SUB-D PLUG
 S8TD37 - INPUT MODULE WITH INTERNAL INLET FOR PILOTING SOLENOID VALVES AND 37-PINS SUB-D PLUG

Weight 110 g

/EX Consistent with the ATEX directive



II 3G c Ex nA IIC T5 Gc -5°C≤Ta≤50°C
 II 3D c Ex tc IIC T100°C IP65 Dc

E.G.: **S8TD37/EX**

INPUT MODULE WITH EXTERNAL INLET FOR PILOTING SOLENOID VALVES - SBTI...

S8TI25 - INPUT MODULE WITH EXTERNAL INLET FOR PILOTING SOLENOID VALVES AND 25-PINS SUB-D PLUG
 S8TI37 - INPUT MODULE WITH EXTERNAL INLET FOR PILOTING SOLENOID VALVES AND 37-PINS SUB-D PLUG

Weight 110 g

/EX Consistent with the ATEX directive



II 3G c Ex nA IIC T5 Gc -5°C≤Ta≤50°C
 II 3D c Ex tc IIC T100°C IP65 Dc

E.G.: **S8TI37/EX**

PNEUMATIC FUNCTIONS*

Symbol	Function	Response time at 6 bar (ms)		Flow rate (NI/min)	Weight (g)	TYPE
		Pilot	Return			
	5/2 monostable	Solenoid (13)	Pneumomechanical spring (38)	750	106	S8A
	5/2 bistable	Solenoid (11)	Solenoid (11)	750	136	S8B
	5/3 closed center	Solenoid (15)	Solenoid (17)	600	146	S8C
	3/2 N.O.+3/2 N.O. = 5/3 pressure centre	Solenoid (15)	Solenoid (17)	600	146	S8E
	3/2 N.C.+3/2 N.C. = 5/3 open centre	Solenoid (15)	Solenoid (17)	600	146	S8F
	3/2 N.C. + 3/2 N.O.	Solenoid (15)	Solenoid (17)	600	146	S8G
	2/2 N.O. + 2/2 N.O.	Solenoid (15)	Solenoid (17)	600	146	S8H
	2/2 N.C. + 2/2 N.C.	Solenoid (15)	Solenoid (17)	600	146	S8I
	2/2 N.C. + 2/2 N.O.	Solenoid (15)	Solenoid (17)	600	146	S8L

*Please contact our sales dept. for the 2/2 + 3/2 pneumatic function

/EX Consistent with the ATEX directive II 3G c Ex nA IIC T5 Gc -5°C≤Ta≤50°C
II 3D c Ex tc IIIC T100°C IP65 Dc

E.G.: **S8F/EX**

VALVE DIMENSIONS

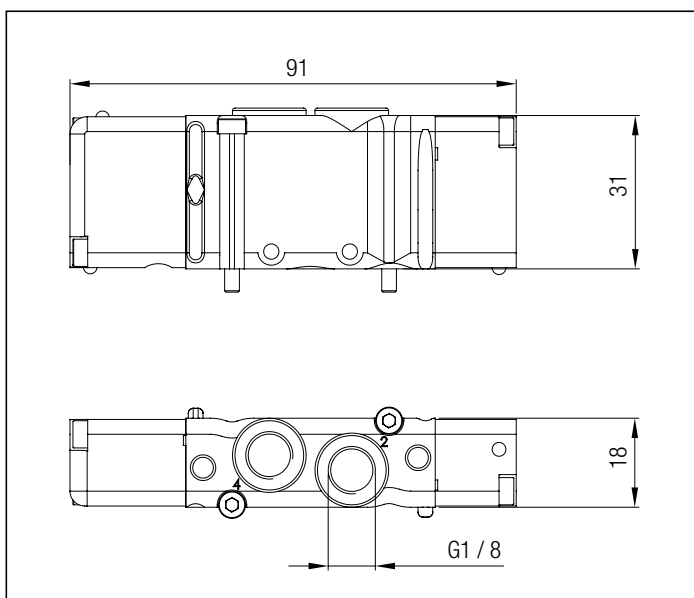

BLANKING PLATE - KIT/PC/S8

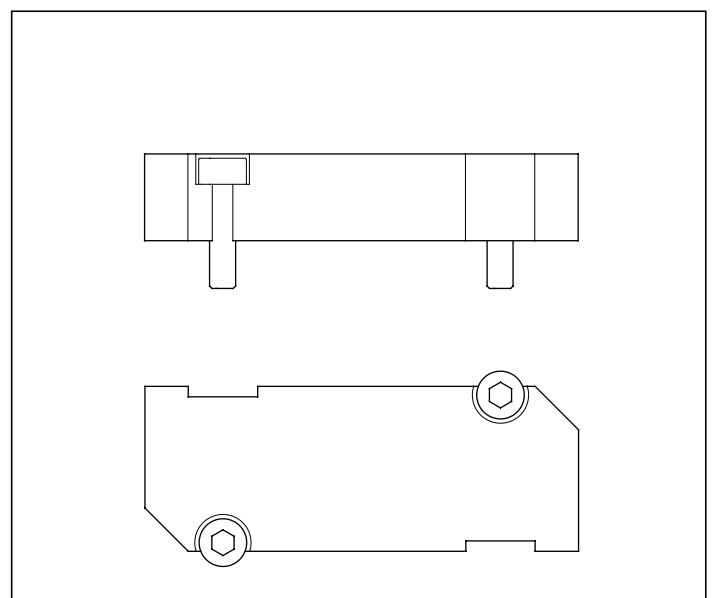

MODULAR BASE WITH SINGLE SOLENOID VALVE AND MONOSTABLE MANUAL ACTUATOR - S81M

Sub-base for valve:
S8A - 5/2 monostable

Weight 75 g

/EX Consistent with the ATEX directive  II 3G c Ex nA IIC T5 Gc -5°C≤Ta≤50°C
II 3D c Ex tc IIIC T100°C IP65 Dc

E.G.: **S81M/EX**

MODULAR BASE WITH DOUBLE SOLENOID VALVE AND MONOSTABLE MANUAL ACTUATOR - S82M

Sub-base for valve:
S8B - 5/2 bistable
S8C - 5/3 closed centre
S8E, S8F, S8G - 2x3/2
S8H, S8I, SBL - 2x2/2

Weight 82 g

/EX Consistent with the ATEX directive  II 3G c Ex nA IIC T5 Gc -5°C≤Ta≤50°C
II 3D c Ex tc IIIC T100°C IP65 Dc

E.G.: **S81M/EX**

INTERMEDIATE BASE WITH AUXILIARY INLETS AND EXHAUSTS - S8M, S8N, S8O, S8P

S8M - INTERMEDIATE BASE WITH THROUGH DUCTS
S8N - INTERMEDIATE BASE WITH DUCT "1" CLOSED
S8O - INTERMEDIATE BASE WITH DUCTS "1", "3" & "5" CLOSED
S8P - INTERMEDIATE BASE WITH DUCTS "3" & "5" CLOSED

S8M

S8N

S8O

S8P

Weight 110 g

TERMINAL MODULE - S8TC

Weight 51 g

TIE RODS FOR MANIFOLD (PAIR) - S8-T...

TYPE	No. OF STATIONS	WHEIGHT (g)
S8-T2	2	24
S8-T4	4	42
S8-T6	6	60
S8-T8	8	78
S8-T10	10	96
S8-T12	12	114
S8-T14	14	132
S8-T16	16	150
S8-T18	18	168
S8-T20	20	186
S8-T22	22	204
S8-T24	24	222
S8-T26	26	240
S8-T28	28	258
S8-T30	30	276

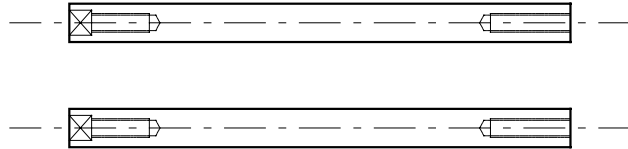

PAIR OF NIPPLES FOR ADD ONE, THREE OR FOUR STATIONS

TYPE	No. OF STATIONS	WHEIGHT (g)
S8-N1	1	5
S8-N3	3	14
S8-N4	4	19

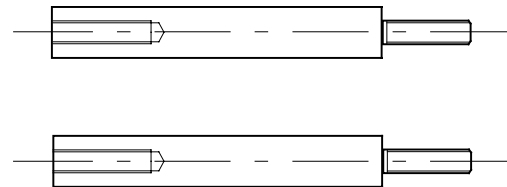

This nipple allows to add a valve station at the end of the manifold, and it's possible to use two or more nipples consecutively

HOW TO CHOOSE THE RIGHT TIE-RODS & NIPPLES

Manifold of 16 stations: use the "S8-T16" tie-rod (16).

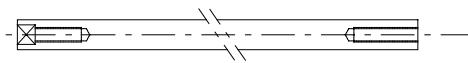

Manifold of 17 stations: "S8-T16" tie-rod + "S8-N1" nipple (16+1).

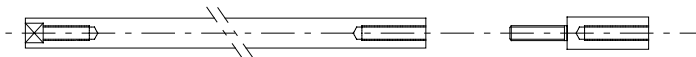

Manifold of 34 stations: "S8-T30" tie-rod + "S8-4" nipple . (30+4)

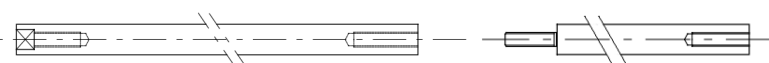

Manifold of 37 stations: "S8-T30" tie-rod + "S8-3" & "S8-4" nipples. (30+3+4)

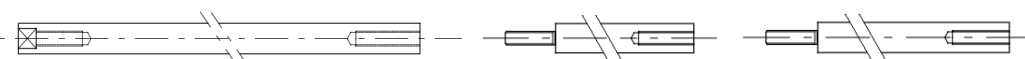

OVERALL DIMENSIONS

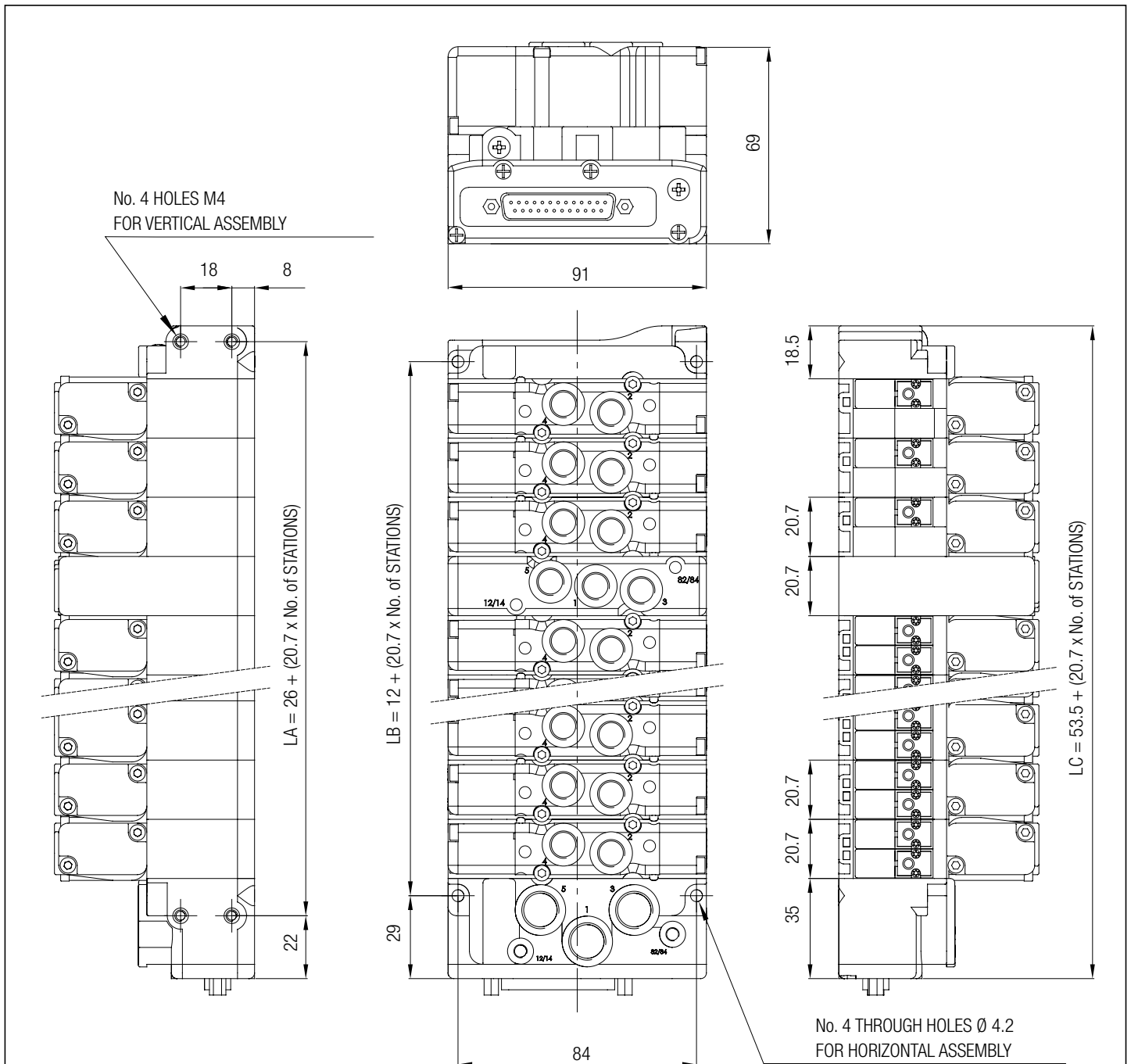

No. of stations	2	3	4	5	6	7	8	9	10	11	12	13	14	15	16	17
LA	67,4	88,1	108,8	129,5	150,2	170,9	191,6	212,3	233	253,7	274,4	295,1	315,8	336,5	357,2	377,9
LB	53,4	74,1	94,8	115,5	136,2	156,9	177,6	198,3	219	239,7	260,4	281,1	301,8	322,5	343,2	363,9
LC	94,9	115,6	136,3	157	177,7	198,4	219,1	239,8	260,5	281,2	301,9	322,6	343,3	364	384,7	405,4

No. of stations	18	19	20	21	22	23	24	25	26	27	28	29	30	31	32
LA	398,6	419,3	440	460,7	481,4	502,1	522,8	543,5	564,2	584,9	605,6	626,3	647	667,7	688,4
LB	384,6	405,3	426	446,7	467,4	488,1	508,8	529,5	550,2	570,9	591,6	612,3	633	653,7	674,4
LC	426,1	446,8	467,5	488,2	508,9	529,6	550,3	571	591,7	612,4	633,1	653,8	674,5	695,2	715,9

STANDARD HORIZONTAL FIXING

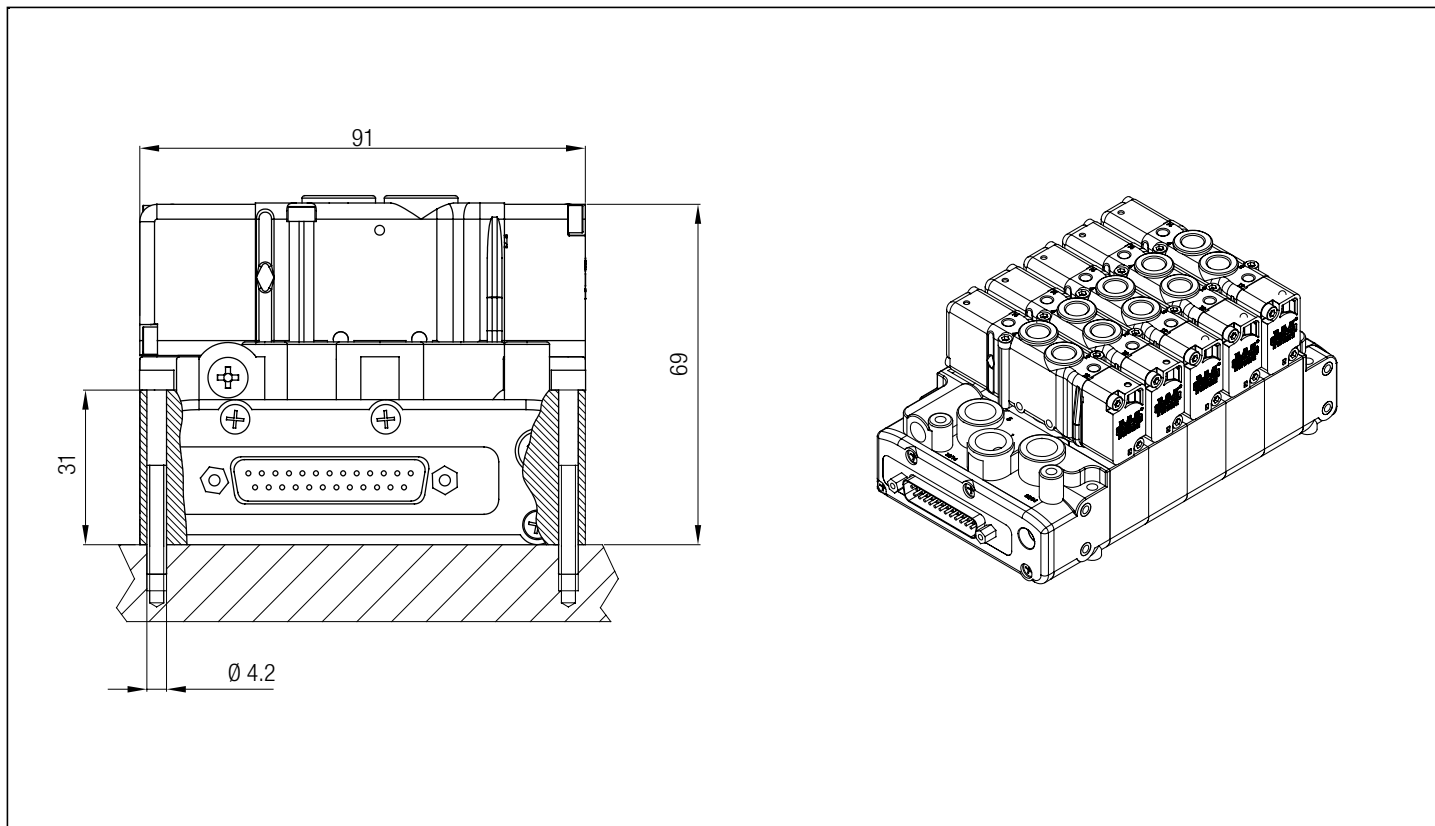

STANDARD VERTICAL FIXING

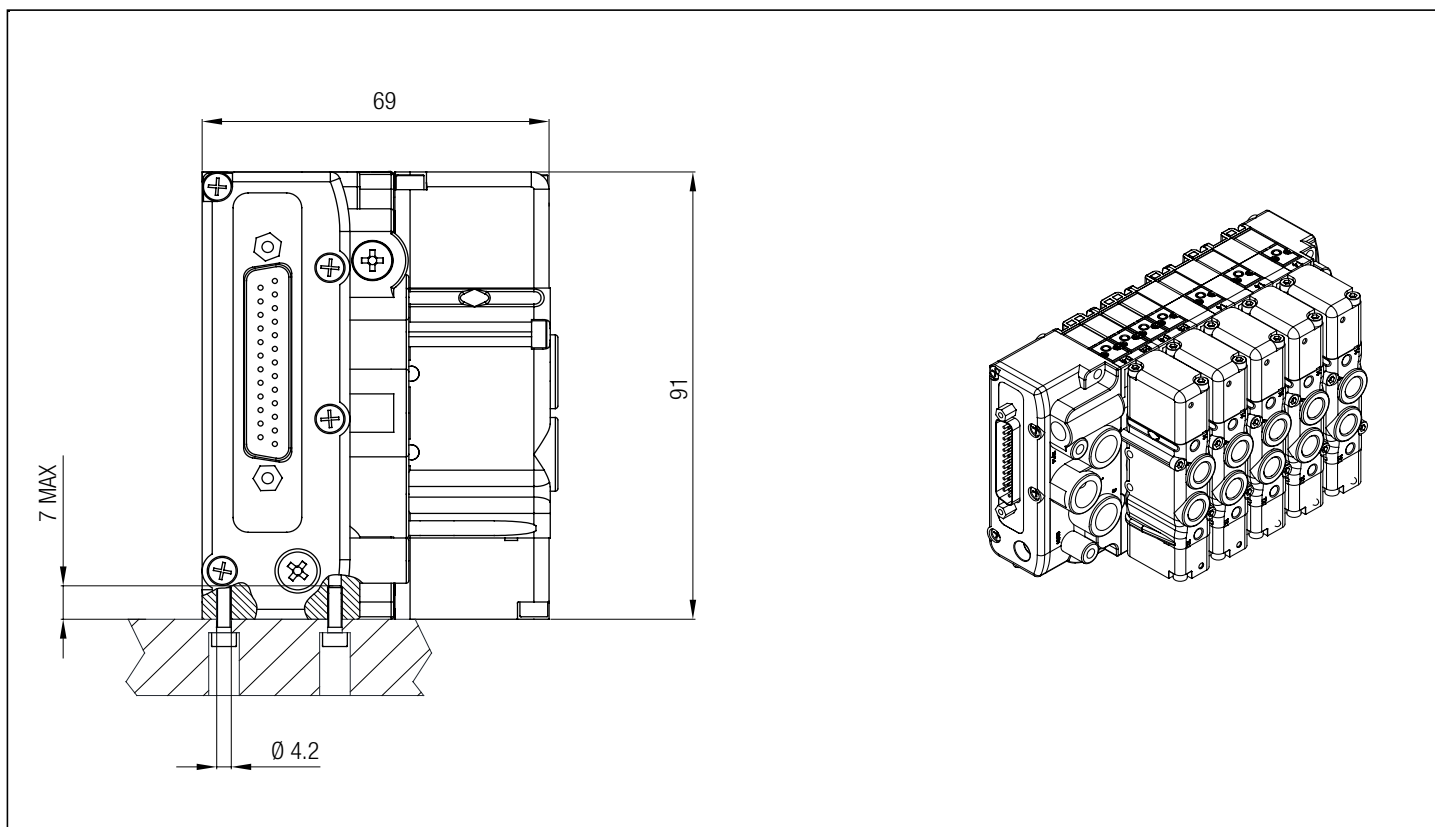

VERTICAL FIXING THROUGH FEET - S8/FP

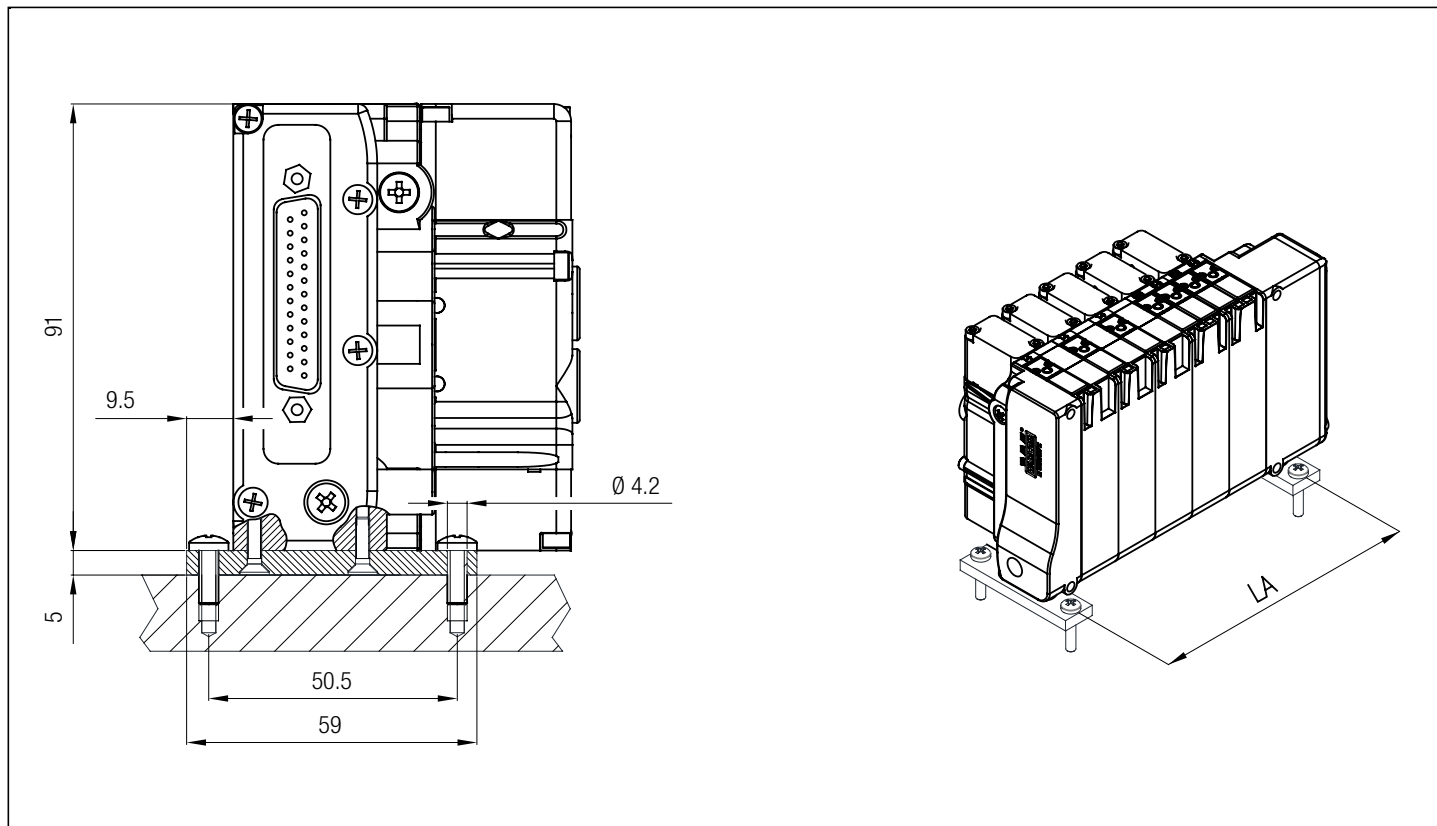

VERTICAL FIXING ONTO DIN RAIL - S8/FD

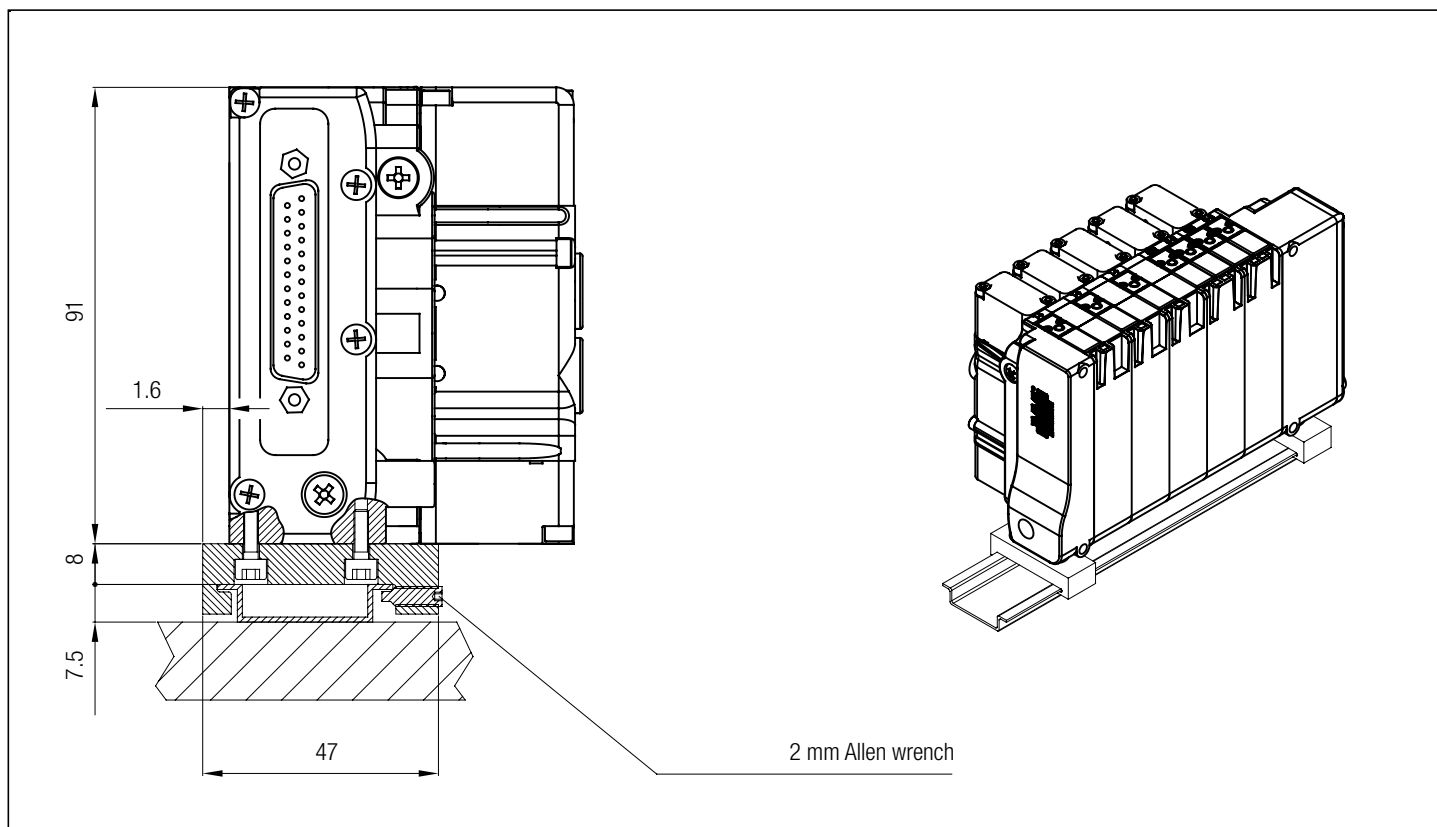

DESCRIPTION

The electrical connection of the manifold of modular valves is automatically made during the assembly of the manifold using the PCBs with male / female connectors housed in each base. Once the manifold is assembled, the electrical components mounted in series are able to manage up to a maximum of 32 electrical signals.

The input module, equipped with 25-pins or 37-pins sub-D plug, defines the maximum number of manageable signals (respectively 22 signals for the input modules "S8TD25" & "S8TI25", and 32 signals for the modules "S8TD37" & "S8TI37").

Each piloting solenoid valve, including resistors and LEDs, requires about 1.44 W (60 mA) and the electrical circuit is designed for not restrict the number of piloting solenoid valves that can be energized simultaneously in the manifold. Each solenoid is also equipped with a system which reduces the higher current peaks up to + 10% of the value of nominal voltage and which prevents the upstream return of the accumulated current that could damage sensitive electrical devices.

The concept of housing the piloting solenoid valve on manifold greatly simplifies the production costs and consequently the spare parts become cheaper. This solution does not allow to use 5/2 monostable valves with a double solenoid base.

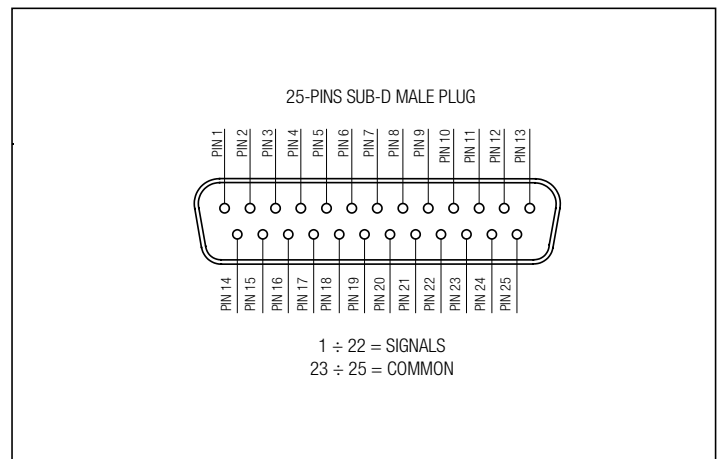
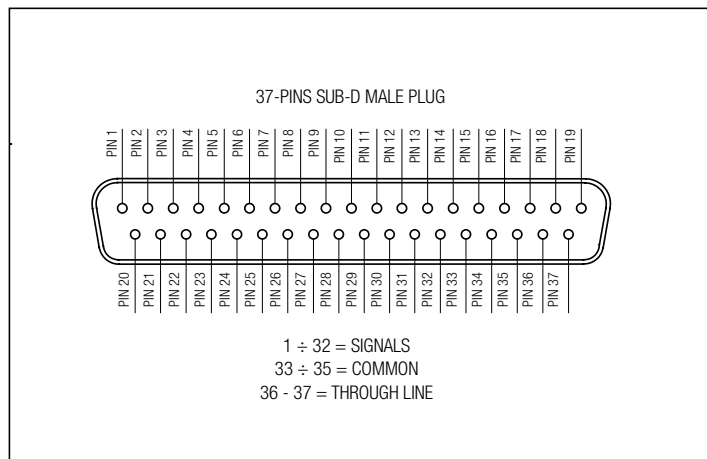

MULTI PIN CONNECTION WITH A MANIFOLD MADE OF ONLY SINGLE SOLENOID BASES

Sub-D 25*				Sub-D 37*			
PIN No.	WIRE COLOUR	SOLENOID No.	VALVE POSITION	PIN No.	WIRE COLOUR	SOLENOID No.	VALVE POSITION
1	White	14	1	1	White	14	1
2	Brown	14	2	2	Brown	14	2
3	Green	14	3	3	Green	14	3
4	Yellow	14	4	4	Yellow	14	4
5	Grey	14	5	5	Grey	14	5
6	Pink	14	6	6	Pink	14	6
7	Blue	14	7	7	Blue	14	7
8	Red	14	8	8	Red	14	8
9	Black	14	9	9	Black	14	9
10	Purple	14	10	10	Purple	14	10
11	Grey/Pink	14	11	11	Grey/Pink	14	11
12	Red/Blue	14	12	12	Red/Blue	14	12
13	White/Green	14	13	13	White/Green	14	13
14	Brown/Green	14	14	14	Brown/Green	14	14
15	White/Yellow	14	15	15	White/Yellow	14	15
16	Yellow/Brown	14	16	16	Yellow/Brown	14	16
17	White/Grey	14	17	17	White/Grey	14	17
18	Grey/Brown	14	18	18	Grey/Brown	14	18
19	White/Pink	14	19	19	White/Pink	14	19
20	Pink/Brown	14	20	20	Pink/Brown	14	20
21	White/Blue	14	21	21	White/Blue	14	21
22	Brown/Blue	14	22	22	Brown/Blue	14	22
23	White/Red		(GND)	23	White/Red	14	23
24	Brown/Red		(GND)	24	Brown/Red	14	24
25	White/Black		(GND)	25	White/Black	14	25
				26	Brown/Black	14	26
				27	Grey/Green	14	27
				28	Yellow/Grey	14	28
				29	Pink/Green	14	29
				30	Yellow/Pink	14	30
				31	Green/Blue	14	31
				32	Yellow/Blue	14	32
				33	Green/Red		(GND)
				34	Yellow/Red		(GND)
				35	Green/Black		(GND)

PIN 1 2 3 : 20 21 22

Position of the solenoid valve

Example of the pneumatic function of the valve

1 2 3 + 20 21 22*

5/2 Monostable (1 solenoid)
5/2 Monostable (1 solenoid)
5/2 Monostable (1 solenoid)
5/2 Monostable (1 solenoid)
5/2 Monostable (1 solenoid)
5/2 Monostable (1 solenoid)

*The input module equipped with the 25-pins Sub-D plug can manage up to 22 solenoids for a total of 22 bases with a single solenoid.
*The input module equipped with the 37-pins Sub-D plug can manage up to 32 solenoids for a total of 32 bases with a single solenoid.

MULTI-PIN CONNECTION WITH A MANIFOLD MADE OF ONLY DOUBLE SOLENOID BASES

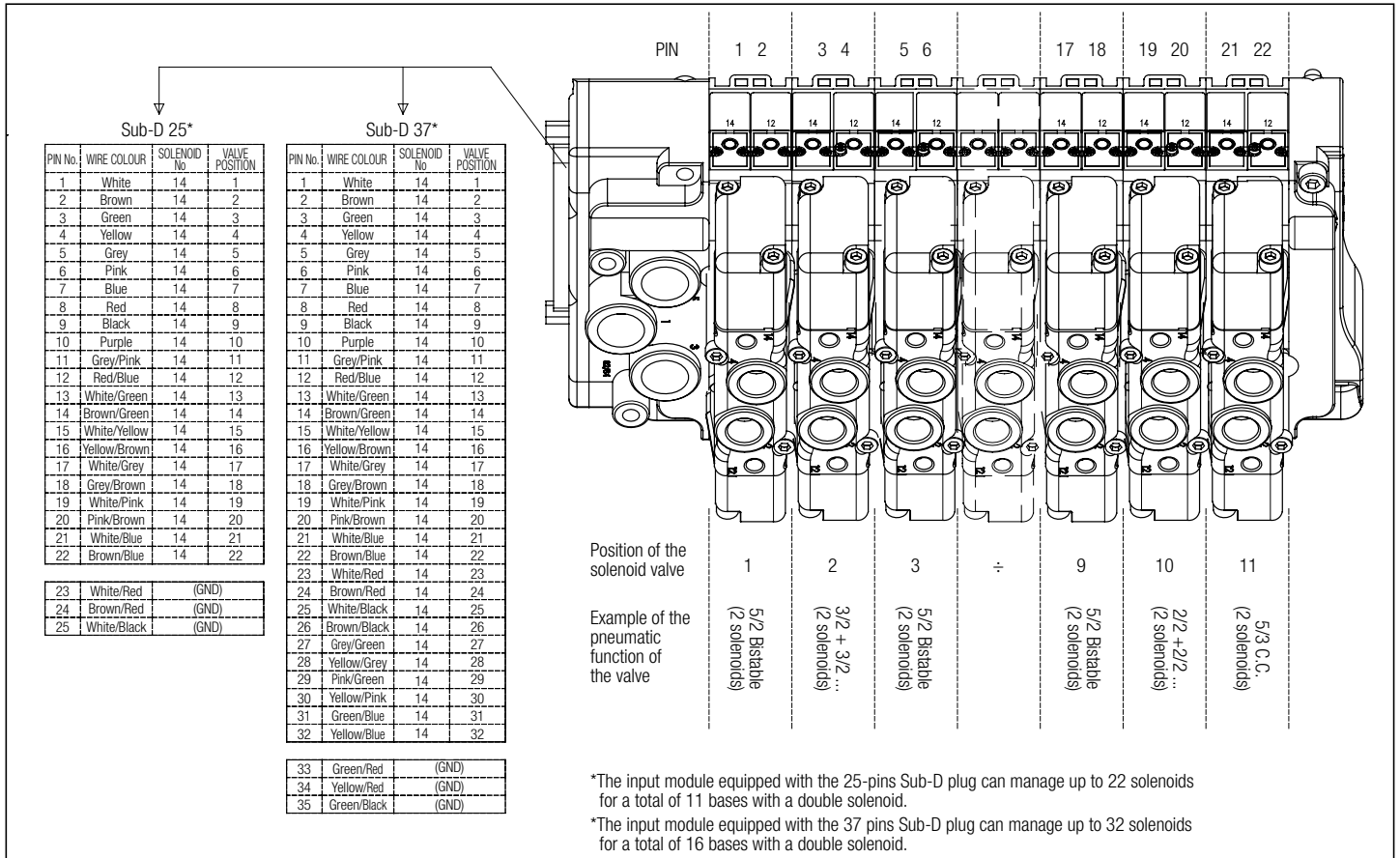

MULTI-PIN CONNECTION WITH A MIXED MANIFOLD MADE OF BOTH SINGLE & DOUBLE SOLENOID BASES AND A INTERMEDIATE BASE

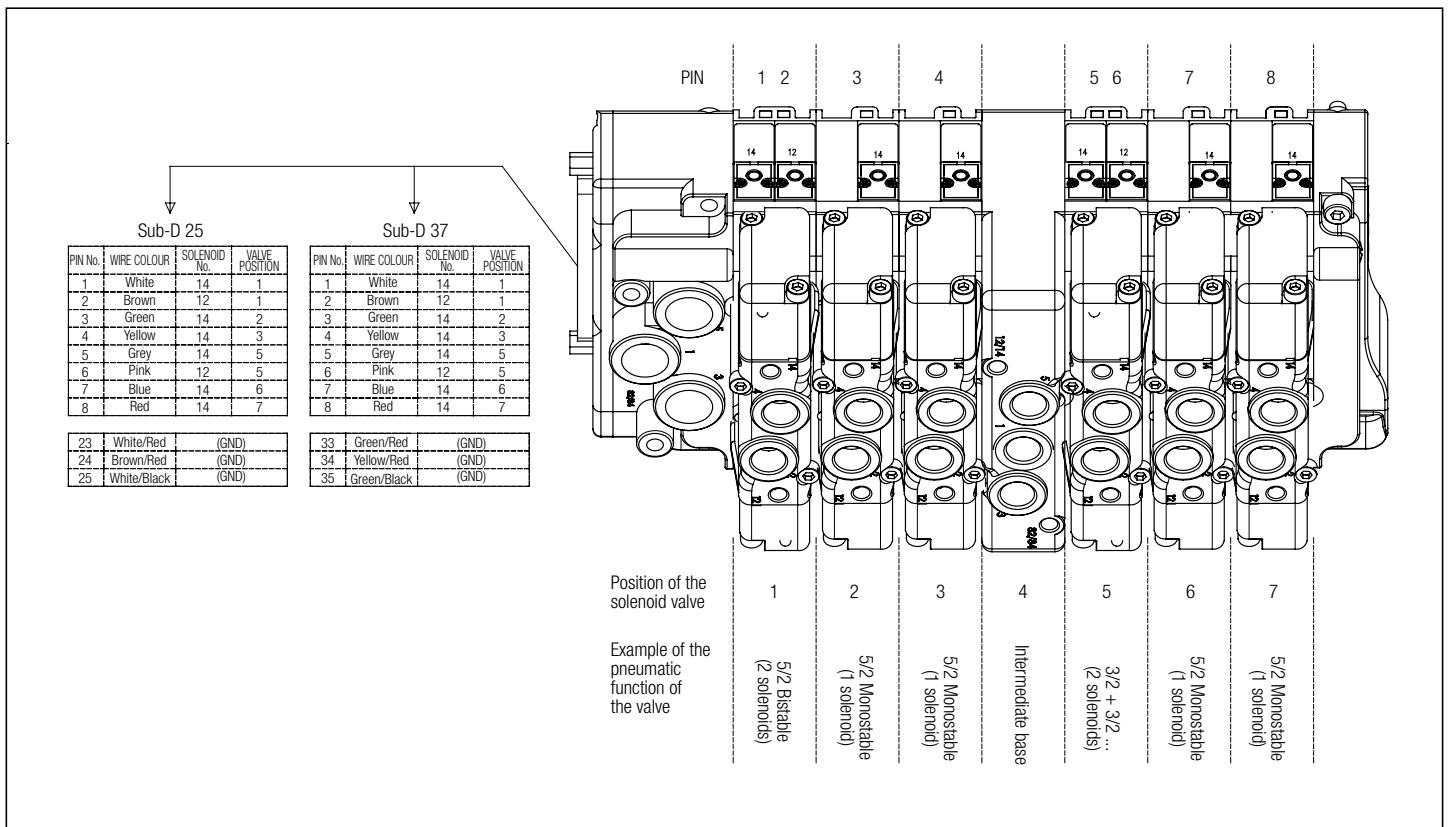

ORDER EXAMPLE OF A MULTI-PIN PNEUMATIC & SOLENOID CONNECTION OF A MIXED MANIFOLD MADE OF: No. 2 SINGLE SOLENOID BASES, No.7 DOUBLE SOLENOID BASES AND No.2 INTERMEDIATE BASES

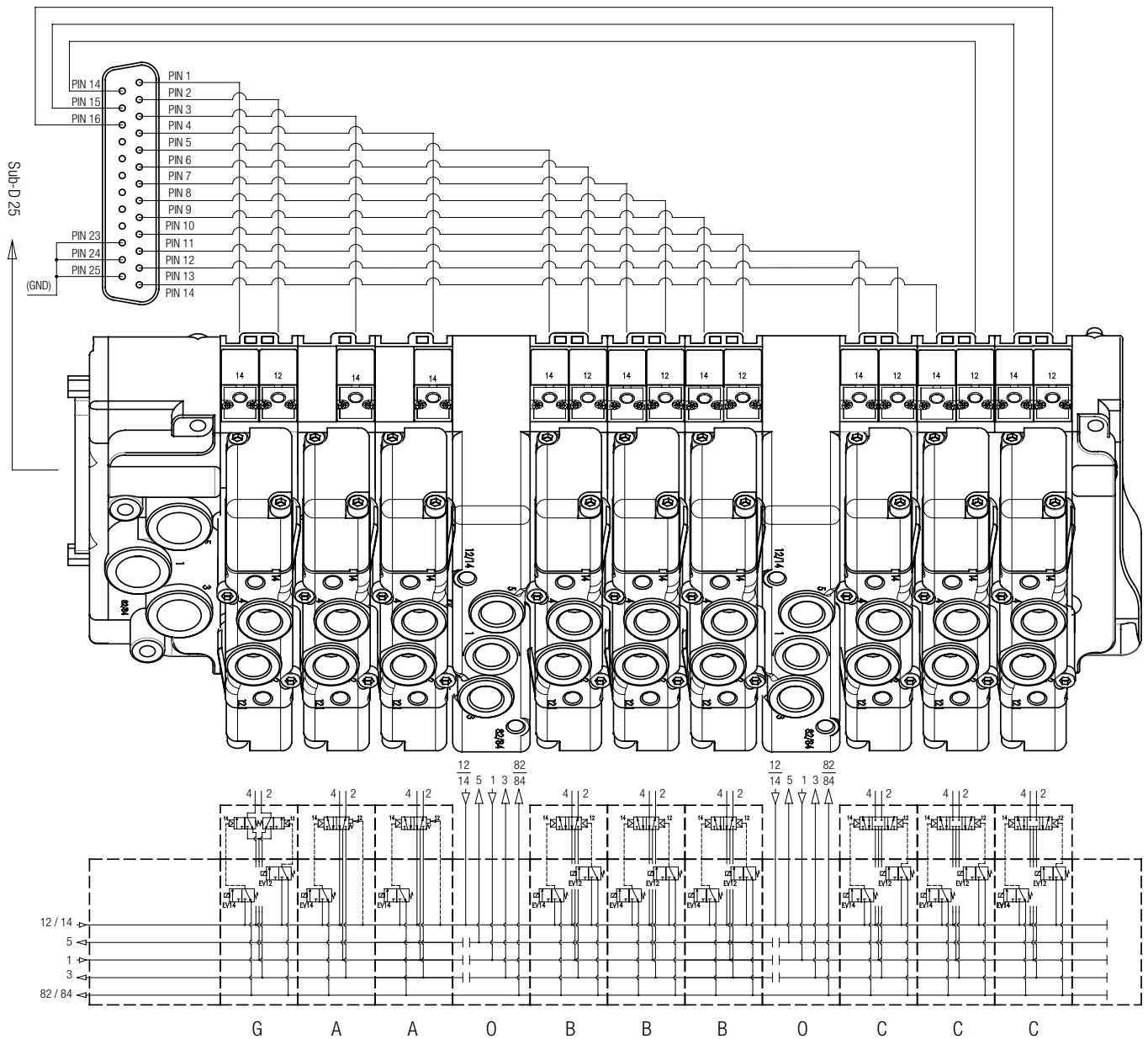
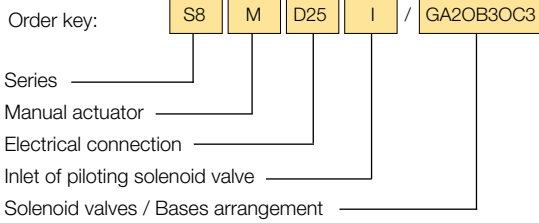

In this example we can see how the two intermediate bases "O" (S80), having the ducts "1", "3" and "5" interrupted, create three zones with independent pressure in the manifold, thus meaning that the common supply pressure of the valves in positions 1, 2 and 3, may be different from one of the valves in positions 5, 6 and 7 and which is even different from the common supply pressure of the valves in positions 9, 10 and 11 but all the valves are still electrically communicating on the same manifold. In all the three zones the external inlet for piloting solenoid valves line, determined by the chosen input module, is in common, so that the pressure in the duct must be properly sized for the correct functioning of the valves. For example: if the first zone works at -1 bar, the second at 2 bar and the third at 6 bar, the piloting pressure must be at least 3.5 bar. See piloting chart on page 3.

IN-LINE SUB-D FEMALE PLUGS

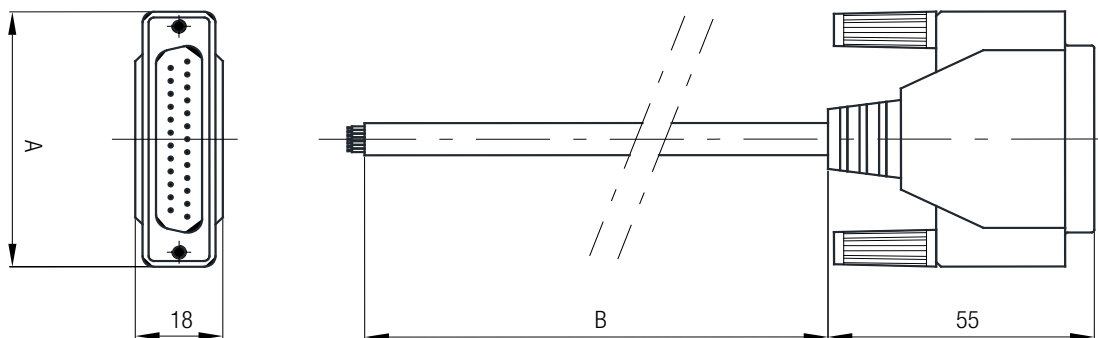

CODE	TYPE	A	B (m)	WEIGHT (g)
MEV/CF3	Sub-D 25	55,5	3	170
MEV/CF5	Sub-D 25	55,5	5	410
MEV/CF10	Sub-D 25	55,5	10	760
MEV/37CF5	Sub-D 37	72,5	5	450
MEV/37CF10	Sub-D 37	72,5	10	800

EVOLUTION IS IN THE AIR



**ITALIAN PNEUMATIC
COMPONENTS
FOR INDUSTRIAL
AUTOMATION**



Waircom M.B.S. S.p.A.
Via Piemonte, 13/15 - 20070 Vizzolo Predabissi (MI) Italy
Ph.: +39 02 98230821 - Fax: +39 02 98230830
www.waircom-mbs.com - info@waircom-mbs.com